



# CM 330 SL

## OPERATING WEIGHT

33 - 34 Tons

## ENGINE POWER

175 kW [238 CV]



ENGINE	
Max power	175 Kw (238 CV) @2300rpm
Cylinders	6 cylinders in line
Power supply	Turbo diesel with intercooler, Common rail
Intake	Two stage air filter
Emissions	In line with EC 97/68 phase 3 EPA NON-ROAD Tier III
Noise level	(EC 2000/14 directive) L <sub>WA</sub> = 101 dB

HYDRAULIC SYSTEM	
Hydraulic pump	Microprocessor controlled Linde with variable flow rate and axial pistons
Max flow rate	620 l/min
Distributor	Linde LS single block proportional 6 component distributor
Operating pressure	330 bars
Operation	Linde Load Sensing operating system Synchron control for synchronised movements without reciprocal influence Special turret rotation motor with independent torque control
Electronic control system	Electronic accelerator, movement speed regulator and auto-idle

TURRET ROTATION	
Hydraulic motor	Axial piston with LS control section and integrated valves
Rotation speed	0-8 rpm, progressive start-up and controlled braking
Reduction	Two stage reduction gear group with tempered gears
Rail bearing	Rail A bearing with steel alloy external teeth, diameter 1380 mm

TRANSMISSION	
Hydraulic motor	Axial piston with variable flow rate (max flow rate 240 l/min)
Transverse movement speed	0-6 km/h in 1 <sup>st</sup> gear; 0-20 km/h in 2 <sup>nd</sup> gear
Gearbox	Two speed, electric drive manual gearbox
Assali	Static 50 ton capacity axles with epicyclic reducer gears in the hubs. Oscillating front axle with electrical locking system. Track width 3.00 m
Wheels	8 wheels with super elastic "Loader" tyres, 12.00x20 on 8.0" HD rims

ARMS	
Total span	11600 mm
Operating range	12700 mm
Arm I°	7000 mm, two cylinder drive
Arm II°	5000 mm monoblock, two cylinder drive

Officine Minelli reserves the right to make any changes it considers appropriate for the improved running of the machine without notice. The information is subject to modification without notice.

Stabilised machine load capacity (kN)

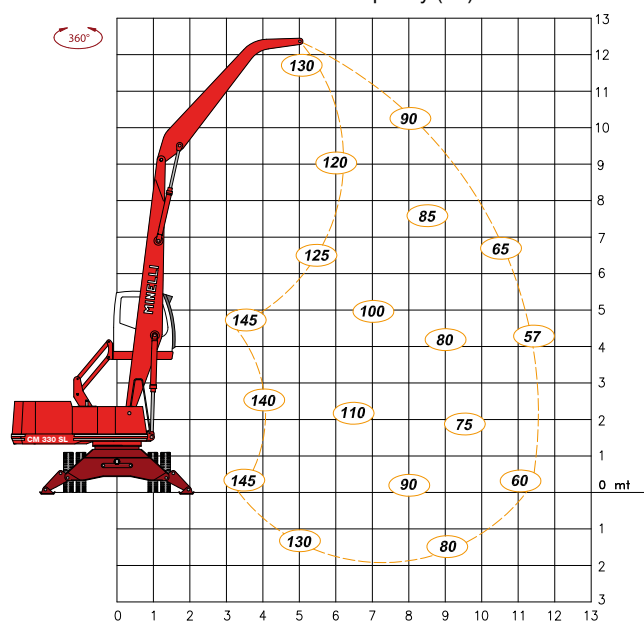

Operating area

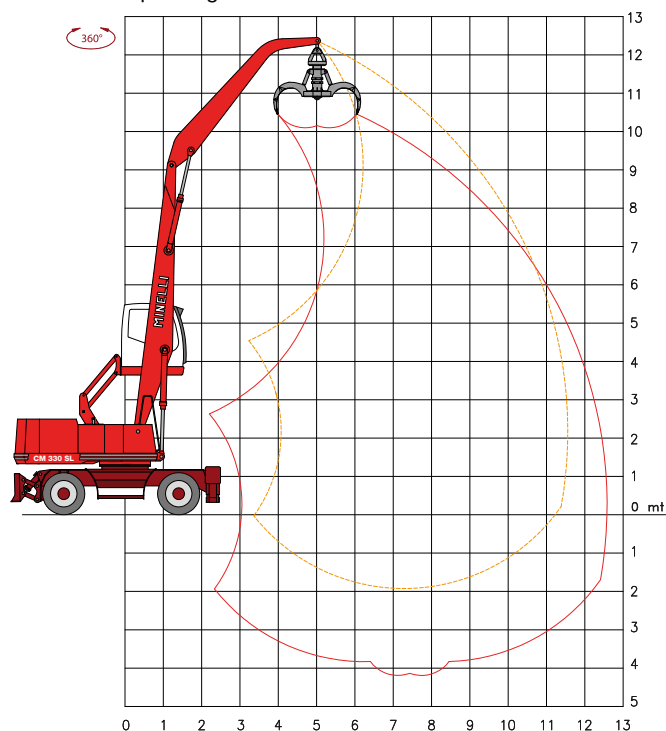

### STANDARD SERIES EQUIPMENT

- Pantograph cabin lift (max height 5.40 m), roll bar grille, spotlights and parasol canopy
- Air conditioning unit with intake micro-filter
- Three speed fan heating system
- Automatic greasing unit for turret and arms
- Low maintenance broad mesh heat exchangers
- Front-mounted hydraulic blade with two cylinders
- Hydraulic rear legs
- Dual traction

### OPTIONAL EQUIPMENT

- Radio with MP3 player
- Seat with pneumatic suspension
- Vortex intake pre-filter
- Hydraulic front legs
- Rubber spacer rings between the wheels
- Electromagnet system and plate
- Various tools available in line with requirements